

W. PORTEOUS.
LATHE TOOL.

No. 427,902.

Patented May 13, 1890.

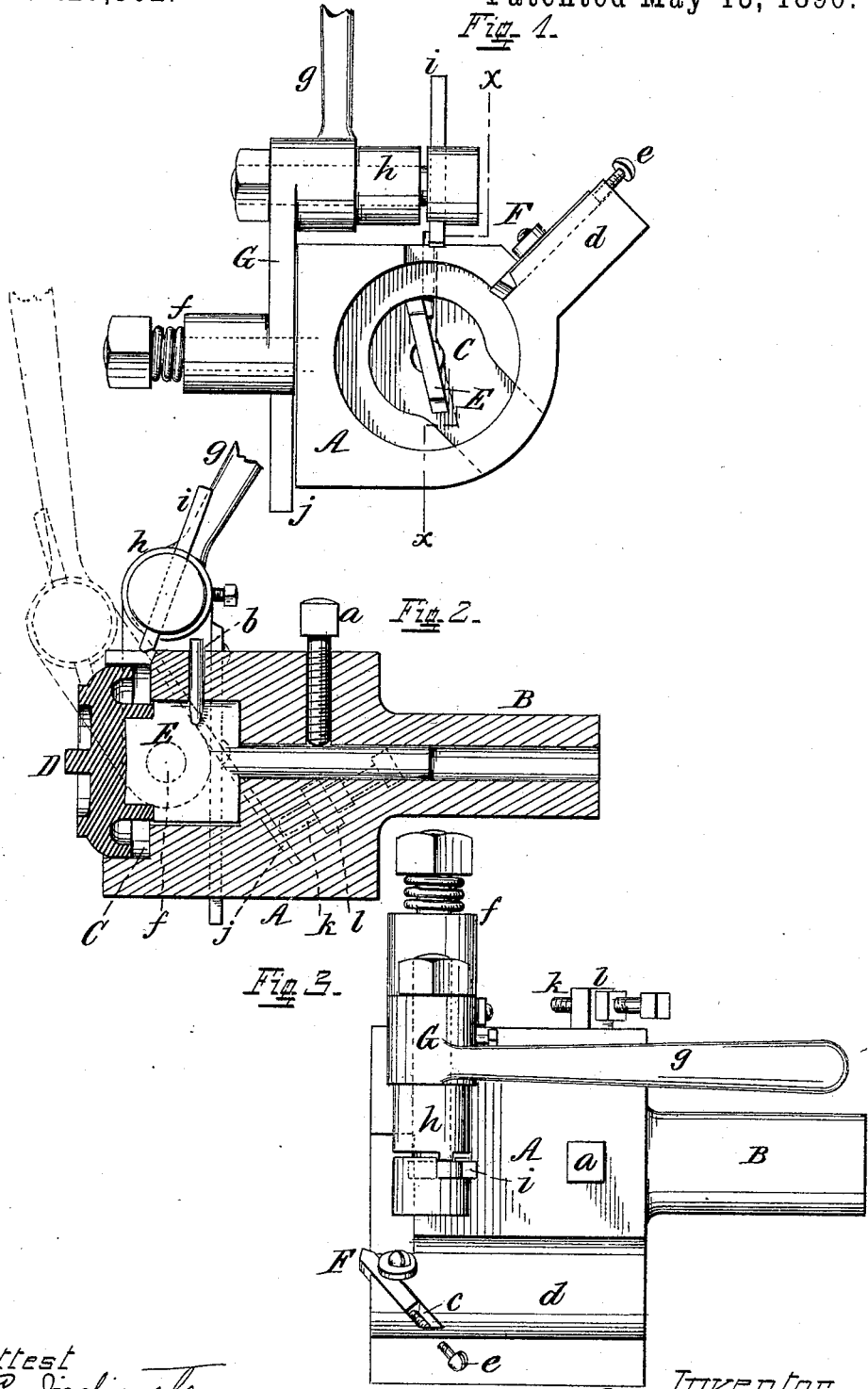

Attest
W.C. Johnston
Chas. Bellon

Inventor
William Porteous
By Peck & Rector his Attys.

W. PORTEOUS,
LATHE TOOL.

No. 427,902.

Patented May 13, 1890.

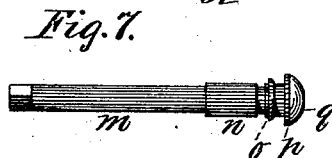
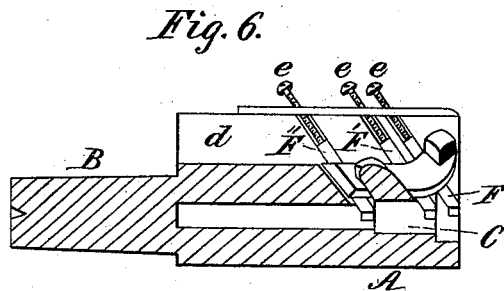
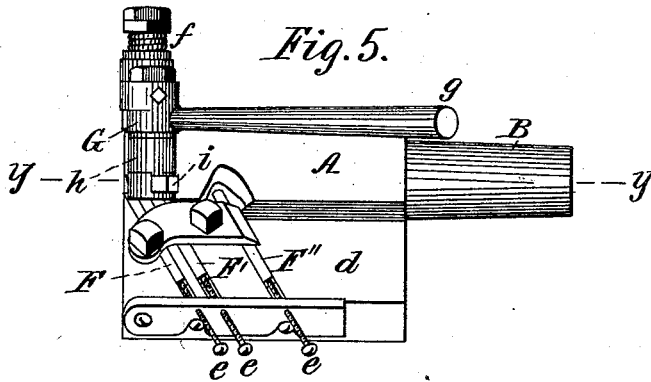
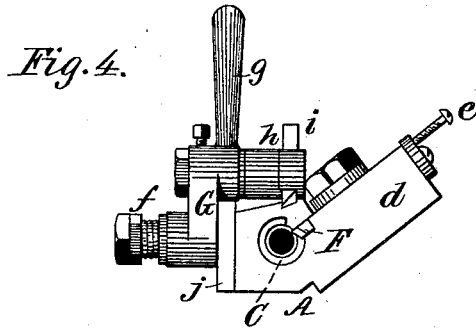

Witnesses:
W. C. Jirdinston.
Charles Bellon

Inventor:
William Porteous
by Peck & Peck
his Attorneys.

UNITED STATES PATENT OFFICE.

WILLIAM PORTEOUS, OF CINCINNATI, OHIO.

LATHE-TOOL.

SPECIFICATION forming part of Letters Patent No. 427,902, dated May 13, 1890.

Application filed November 2, 1889. Serial No. 329,011. (No model.)

To all whom it may concern:

Be it known that I, WILLIAM PORTEOUS, a citizen of the United States, residing at Cincinnati, in the county of Hamilton and State of Ohio, have invented certain new and useful Improvements in Lathe-Tools, of which the following is a full, clear, and exact description, reference being had to the accompanying drawings, forming part of this specification.

My invention relates to that class of lathe-tools for insertion in a sliding head, usually a monitor, to be advanced up to and operate upon the work, which is secured to and revolved by the lathe-spindle.

It has for its object the improved construction of such tools, whereby their capacity and efficiency are increased.

The novelty of my invention will be hereinafter set forth, and specifically pointed out in the claims.

In the accompanying drawings, Figure 1, Sheet 1, is a front elevation of a tool embodying my invention. Fig. 2, Sheet 1, is a side elevation of the tool, in section, through the dotted line *xx* of Fig. 1. Fig. 3, Sheet 1, is a plan view of the tool. Fig. 4, Sheet 2, is a front elevation of a tool in modified form embodying my invention. Fig. 5, Sheet 2, is a plan view of the same. Fig. 6, Sheet 2, is a side elevation of the same, in section, through the dotted line *yy* of Fig. 5. Fig. 7, Sheet 2, is an elevation of a valve-stem operated on by the tool shown in Figs. 4, 5, and 6.

The same letters of reference are used to indicate identical parts in all the figures.

The body A of the tool is a metal block having a shank B for insertion in the monitor or sliding head, and having a recess C on its front face into which the work revolved by the lathe-spindle enters to be acted on by the cutters carried by the tool.

In Figs. 1, 2, and 3 the tool is adapted to dress at one operation five faces of a valve-disk casting D. (Shown in Fig. 2.) Here there is a central cutter E, secured in the recess C by a set-screw *a*, and held from chattering by a pin *b*. This cutter dresses the rear edge and interior of a collar or boss upon the disk

D, while an adjustable inclined cutter F, contained in a recess *c*, Fig. 3, in a projecting flange *d*, and adjusted by a set-screw *e*, dresses the flat edge of the disk above its seat.

Pivoted to the side of the body, as at *f*, is a swinging arm G, provided with an operating-handle *g* and a lateral projection *h*, to which is removably and adjustably secured a cutter *i*, having in this instance two cutting-edges, and which is adapted to be swung by grasping the handle *g* so as to cut the curved seating part of the disk and the flat side of the collar beneath the same, as indicated by the dotted lines in Fig. 2. The lower part of the arm G has a projection *j*, which when the arm is swung forward to the proper limit comes in contact with a set-screw *k*, (dotted lines Fig. 2,) inserted through a lug *l* on the side of the body, and thus arrests the further forward movement of the cutter *i*.

In Figs. 4, 5, and 6 the tool is shown somewhat modified to dress five surfaces of the valve-stem and valve represented by Fig. 7. Here the cutter E is omitted, and in addition to the stationary cutter F there are two other similar stationary cutters F' F'', of which F' dresses the smaller part *m* of the spindle F'', the larger parts *n* *o*, and F the part *p*, while the swinging cutter *i* dresses the rounded or seating part of the valve.

I am aware of the construction shown in Patent No. 177,992, of May 30, 1876, and do not claim the same. It is to be observed that in said patent the work is held between centers, while the cutting-tools are all at one side, so that in case of thin work there is liability of irregularity of cutting from chattering. By my construction, however, the work is incased within the recessed body and supported at all points, so that no flexure whatever can occur.

Having thus fully described my invention, I claim—

1. In a lathe-tool, the combination, with the recessed body and one or more stationary cutters, of a swinging cutter whose support is pivoted and secured upon the body, substantially as described.

2. In a lathe-tool, the combination, with

the recessed body and one or more stationary cutters, of a swinging cutter whose support is pivoted and secured upon the body, and a stop for said swinging cutter, substantially as described.

5 3. The combination, with the recessed body A, provided with one or more stationary cutters, of the pivoted swinging arm G, pro-

vided with a handle *g*, and projection *h*, and the cutter *i*, secured to the projection *h*, substantially as and for the purpose described. 10

WM. PORTEOUS.

Witnesses:

CHAS. M. PECK,
FRED HOLZ.